



DURA PRODUCTS

Technology with Lasting Value

MINI CATALOG

Market Leader
in agricultural transfer systems

IF YOU ARE LOADING A SPRAYER, DURA PRODUCTS HAS A SOLUTION FOR YOU

Fast. Simple. Safe.™

Dura Products provides a variety of chemical mixing and loading solutions. Choosing a Dura Product solution is essential for successful delivery of your chemicals. Understanding your requirements and compatibility is crucial before making a purchase.



Customer Benefits

Fast

Simple

Safe

 Number of Chemicals to Blend at same time

 Speed to fill*

 Reduce operator mistakes

 Increase Accuracy

 Reduce chemical exposure

 Recirculation

*4 Bulk Products

OR YOU.

ons that fit your needs.
of chemicals.
making a selection.

 <p>Page 16</p>	 <p>Page 7</p>	 <p>Page 8</p>	 <p>Page 4</p>
<p>Easy Caddy</p>	<p>Auto-Batch Easy Caddy</p>	<p>Auto-Batch Control Valve</p>	<p>Auto-Batch Direct Injection</p>
<p>1</p>	<p>1</p>	<p>1</p>	<p>4+</p>
<p>20</p>	<p>20</p>	<p>10</p>	<p>5</p>
<p>Simple chemical measuring</p>	<p>Simple chemical batching</p>	<p>Chemical batching with inductor</p>	<p>Simple to program and run batches</p>
<p>No jug dumping</p>	<p>No jug dumping</p>	<p>Closed Transfer</p>	<p>Closed Transfer</p>
<p>Optional</p>	<p>Optional</p>	<p>No</p>	<p>Yes</p>

DURA AUTO-BATCH™ DIRECT INJECTION



Fast. Simple. Safe.™

The Dura **Auto-Batch™** Direct Injection works by direct injecting herbicides into the carrier flow while filling the sprayer.

**Increase
PROFITABILITY**
with a Dura **Auto-Batch™**
Direct Injection



How It Works

- 1 Select the volume desired
- 2 Press START
- 3 The pump will begin to inject fluid then automatically shut off upon completion



- Lowest cost automated sprayer filling system
- Filling your sprayer has never been easier or faster
- Reduces operator error and herbicide exposure
- Provides recirculation, maximizing chemical performance
- Accurately dispenses repeatable batches
- Eliminates cross contamination



Video available at
DuraProducts.com/videos

ORDERING INFORMATION	
PRODUCT #	DESCRIPTION
DPAB-DI2V-12	2" Plumbed AB Direct Inject System 12V Viton® 4 pump
DPAB-DI2E-12	2" Plumbed AB Direct Inject System 12V EPDM 4 pump
DPAB-DI3V-12	3" Plumbed AB Direct Inject System 12V Viton® 4 pump
DPAB-DI3E-12	3" Plumbed AB Direct Inject System 12V EPDM 4 pump
DPAB-DI2V-110	2" Plumbed AB Direct Inject System 110V Viton® 4 pump
DPAB-DI2E-110	2" Plumbed AB Direct Inject System 110V EPDM 4 pump
DPAB-DI3V-110	3" Plumbed AB Direct Inject System 110V Viton® 4 pump
DPAB-DI3E-110	3" Plumbed AB Direct Inject System 110V EPDM 4 pump

* 1-3 pumps can still be ordered. Use selection charts found at duraproducts.com

What a **Real User** is saying about the **Dura Auto-Batch™ Direct Injection**...



Reduced our sprayer load time by more than 78%.
 -Woodward Farms

Automated Direct Injection Fill Using **Dura Auto-Batch™ Direct Injection**

Austin Woodward · Woodward Farms

Hagie STS12, 1200 Gallon Capacity, 3" Plumbing

PRODUCTS DIRECT INJECTED			PRODUCTS INDUCED
Atrazine 4L	27.5 gal per fill	1 qtA	<i>Callisto (added from 1 gal jug)</i>
Durango DMA	20.5 gal per fill	1.5 ptA	<i>Zidua SC (added from 1 gal jug)</i>
Class Act NG	20.5 gal per fill	1.5 ptA	<i>Interlock (added from 2.5 gal jug)</i>

68.5 GALLONS OF PRODUCT INJECTED INTO CARRIER STREAM WITH AUTO-BATCH™ DIRECT INJECTION

Dura Auto-Batch™ Direct Injection Time 3 minutes 45 seconds

Sprayer Fill Time 6 minutes 15 seconds

"When it comes to spraying we want to be safe and quick. With the Dura Auto-Batch™ Direct Injection, we not only have less exposure to chemicals, but we've reduced our sprayer load time by more than 78%."

- Austin Woodward, Woodward Farms

- Always turn pump off and disconnect system from power when not in use.
- Never leave unattended while in use.
- Always close manual valves at the bottom of the system when not in use.

The Dura Auto-Batch™ Direct Injection gives you a high return on your investment.



Calculate your own Additional Spraying Capacity with the
Dura Auto-Batch™ Direct Injection

Additional Spraying Capacity per Day		Woodward Farms Savings	Your Savings
System Sprayer Fill Time (mins)		20 min	
Dura Auto-Batch™ Direct Injection Sprayer Fill Time (mins)	-	6.25 min	6.25
Mins Saved per Fill	=	13.75 min	
Fills per Day	x	5	
Mins Saved per Day	=	68.75 mins	
Acres Sprayed per Hour		100.00 ac	
Additional Capacity per Day*		115.00 ac	
Chemical Application Rate / Acre**	x	8.01	
Spraying Days	x	9.00	
Savings After 9 Spraying Days	=	\$ 8,290.35	\$

*minutes saved per day / 60 x acres sprayed per hour

**2023 Indiana Farm Custom Rates (Purdue University)

Video available at
DuraProducts.com/videos



DURA AUTO-BATCH™ EASY CADDY

Fast. Simple. Safe.™

Tanks, Totes and Drums sold separately.



"The system **reduces** human error and creates valuable **efficiency** for us."

-Peterson Farms, KY



- Intuitive interface allows for the selection of manual or automatic operation with the press of a button
- High-flow pump with up to 18GPM/68LPM flow rate
- Optimized for repeatable batching; returns to the last volume amount dispensed
- 100% moisture-sealed circuitry
- Includes Dura **Auto-Batch™** Meter with impact resistant Lexan™ faceplate
- Available in 12 Volt or 110 Volt, and Viton®, EPDM, or Silicone options
- Measures in gallons, liters and ounces
- Includes a 2-year Warranty & Maintenance Program

How It Works

- 1 Select the volume desired
- 2 Press START
- 3 The pump will begin to dispense fluid then automatically shut off upon completion



"I've got six plumbed to an inductor. It **works** great, and **saves** me time when mixing batches."

-Don, Nutrien Ag Solutions



ORDERING INFORMATION

12 VOLT	110 VOLT
DPABS-6318V-12 Viton®	DPABS-6318V-110 Viton®
DPABS-6318E-12 EPDM	DPABS-6318E-110 EPDM
DPABS-6318S-12 Silicone	DPABS-6318S-110 Silicone

Always turn pump off and disconnect system from power when not in use.



DURA PRODUCTS
Technology with Lasting Value

DURA-ABV-B

**AUTOMATION
MADE EASY**

BANJO EVX® 100B*

AUTO-BATCH™ METER

ELECTRIC VALVE



*Available in Manifold

SIMPLE

SMART

ECONOMICAL

- Join factory installed electric connectors
- Plumb valve to Auto-Batch
- Select volume desired
- Press START
- Banjo EVX® Valve will open, fluid is measured and valve automatically closes upon completion

- Eliminates operator error and herbicide exposure
- Real-time valve LED performance feedback
- Inventory management
- Female NPT and manifold flange connections offer plumbing options
- Ability to save up to five calibrations and measure in gallons, liters and ounces

- Consists of a Dura Auto-Batch™ Control Valve meter, Banjo EVX® Valve and plumbing kit.
- No sophisticated wiring, PLC or plumbing
- Multiple units can be used in manifold application
- Ideally suited with venturi driven chemical handling system

DURA AUTO-BATCH™ CONTROL VALVE

Fast. Simple. Safe.™



How It Works

- 1 Select the volume desired
- 2 Press START
- 3 Banjo EVX® Valve will open, fluid is measured and valve automatically closes upon completion

Dura Auto-Batch™ Control Valve TECHNICAL SPECIFICATIONS

Operating Temp	-10° F to 130° F, -23° C to 54° C
Flow Rate	2 to 22GPM, 7.5 to 83LPM
Meter Accuracy	+/- .5%
Backlit LCD Display	Yes; with back-light timeout
Max Pressure	40 PSI
Power Source	4 "AAA" batteries; strength indicator
Wetted Materials	Polypropylene; 304 Stainless Steel; Ryton; Viton® seals
Housing Chamber	Polypropylene
Moisture Sealed	Yes; with sealed circuitry
Batch Count	Yes
Total Count	Yes
Units Measured	Gallons, Liters and Ounces
Chemically Resistant	Yes
Calibration	Preset, Quick List or Manual
Saved Calibrations	5
Dimensions	5¼" W x 7¼" H x 4¼" D
Weight	1.5 lbs



ORDERING INFORMATION

PRODUCT #	DESCRIPTION
DURA-ABV-B	Dura Auto-Batch™ Control Valve meter with Banjo Connector
BANJO MEVX100B	1" Full Port Banjo EVX® Valve with connector
DURA-ABV MEVX CONNECTOR KIT	Accessory Plumbing Kit



Video available at
DuraProducts.com/videos

2" AND 3" AUTO-BATCH™ HIGH-FLOW SYSTEM

Fast. Simple. Safe.™

Auto-Batch™ Features

- Controls carrier flow using a 12-volt DC electric ball valve
- Easily select manual or automatic operation
- Returns to last volume amount dispensed for easy repeatable batching
- Displays message when batch is completed
- Relief valve plumbing kit for use with electric valve
- Banjo® EVX® 2" or 3" Valves available for tank bypass system



Special Features

- Field serviceable
- 100% moisture-sealed circuitry
- Ability to save up to five manual calibrations
- Option to display batch volume, total volume, and flow rate
- Volume measured can be displayed in Liters or Gallons
- Faceplate can be rotated in 90 degree increments
- Ability to calibrate allows for industry minimum straight line before/after meter

ORDERING INFORMATION

2"	DPAB-HFM2KITV Viton®	DPAB-HFM2KITE EPDM
3"	DPAB-HFM3KITV Viton®	DPAB-HFM3KITE EPDM

KIT CONTAINS

Valves	Custom Pressure Relief & Electric Valve
Meter	Auto-Batch™ High-Flow Meter
Other	All hose clamps, gaskets, reducer couplings, and tees.

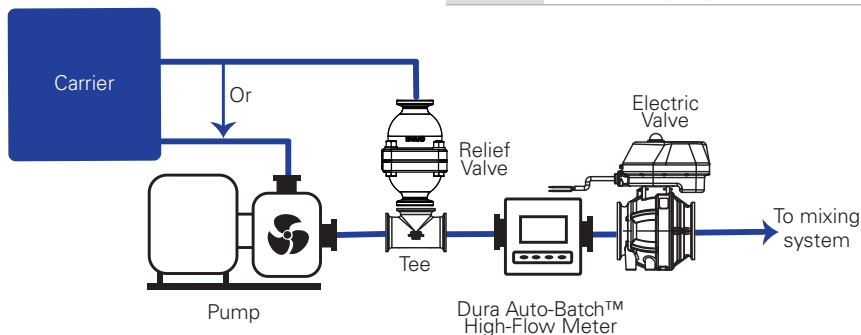



ORDERING INFORMATION		
	PRODUCT #	DESCRIPTION
2"	DPAB-HFM2PRV	2" Relief Valve Plumbing Kit
3"	DPAB-HFM3PRV	3" Relief Valve Plumbing Kit

ORDERING INFORMATION		
	PRODUCT #	DESCRIPTION
2"	MEVX220-DP	2" Full Port Banjo EVX® Valve with Connector
3"	MEVX300-DP	3" Full Port Banjo EVX® Valve with Connector

RELIEF VALVE KIT CONTAINS	
Valve	Pressure Relief*
Other	All hose clamps, gaskets, reducer couplings, and tees.

*Note: Must use Dura custom relief valve



ORDERING INFORMATION		
2"	DPAB-HFM2V Viton®	DPAB-HFM2E EPDM
3"	DPAB-HFM3V Viton®	DPAB-HFM3E EPDM

SPECIFICATIONS	2"	3"
Nominal Size	2"	3"
Model	DPAB-HFM2	DPAB-HFM3
Connection	M220 flange	M300 flange
Meter Accuracy	+/- 0.5%*	+/- 0.5%*
Fluid Flow Initiates Measurement	Yes	Yes
Battery Size/Voltage	(2) 9 Volt	(2) 9 Volt
Battery Life Indicator	Yes	Yes
Backlit Display	Yes	Yes
Maximum Pressure	150 PSI	150 PSI
Minimum GPM	40	80
Maximum GPM	300	700
Minimum Temp	+ 32 °F	+ 32 °F
Maximum Temp	+ 140 °F	+ 140 °F
Meter Type/Style	Paddlewheel	Paddlewheel
Body Construction Material	GF Polypropylene	GF Polypropylene
Paddle Wheel Bearing	Sapphire	Sapphire

* With manual calibration

2" High-Flow
Dura-Meter™



2" AND 3" HIGH-FLOW DURA-METER™

- Intuitive menu-driven backlit display
- Impact resistant Lexan™ faceplate
- 100% Moisture-sealed circuitry
- Multiple plumbing options
- Includes a 2-year Warranty & Maintenance Program

Special Features

- Easily serviced
- Extended battery life with use of (2) 9V batteries
- Fluid flow initiates measurement
- Versatile plumbing configurations
- Displays batch and total volume
- Gallons / Liters flow rate measurement

3" High-Flow
Dura-Meter™



Note: See page 11 for specifications.

ORDERING INFORMATION

2"	DP-HFM2V Viton®	DP-HFM2E EPDM	DP-HFM2S Silicone
3"	DP-HFM3V Viton®	DP-HFM3E EPDM	DP-HFM3S Silicone

DRONE FILL KITS

- Softer fluid transfer without causing shear on the encapsulation
- Self-priming diaphragm with internal by-pass
- High-flow Dura-Pump 15gpm mounted in Easy Caddy frame.
- Kit comes with 20' discharge, 5' suction hose and required fittings
- Includes key FOB (12V only) to enable and disable power to the pump remotely.
- Standard discharge ball valve nozzle
- Optional 3/4" poly auto-nozzle with stainless steel spout*
- Includes a 2-year Warranty & Maintenance Program



*Optional auto-nozzle



ORDERING INFORMATION	
PRODUCT #	DESCRIPTION
DP-N4005	DEF Poly Auto Shut-off Nozzle w/Stainless Spout and Swivel

ORDERING INFORMATION	
12 VOLT	110 VOLT
DPDRONE-6018V-12 Viton®	DPDRONE-6018V-110 Viton®

Always turn pump off and disconnect system from power when not in use.

DURA-METER™



- Made of impact resistant Lexan™ faceplate
- 100% moisture-sealed circuitry
- Menu driven backlit display
- Plumbed both for in-line and 90-degree applications
- Includes a 2-year Warranty & Maintenance Program



SPECIFICATIONS

Operating Temp	-10°F to 130°F, -23°C to 54°C
Flow Rate	2 to 20 GPM, 7.5 to 75.7 LPM
Meter Accuracy	+ / - .5%
Backlit Display	Yes
Maximum Pressure	40 PSI
Wetted Materials	Polypropylene; 304 Stainless Steel; Ryton; Viton®, EPDM, or Silicone seals

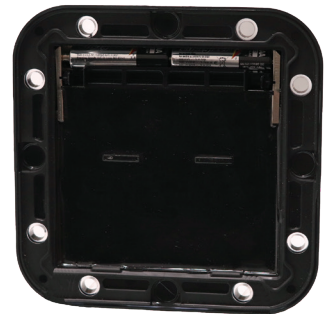

Customer should always check calibration before use.

Special Features

- Extended battery life with use of 4 "AAA" batteries
- Faceplate over-molded with Santoprene and filled with gel for improved shock resistance

ORDERING INFORMATION

DP-3000V
Viton®

DP-3000E
EPDM

DP-3000S
Silicone

DURA-PUMP™

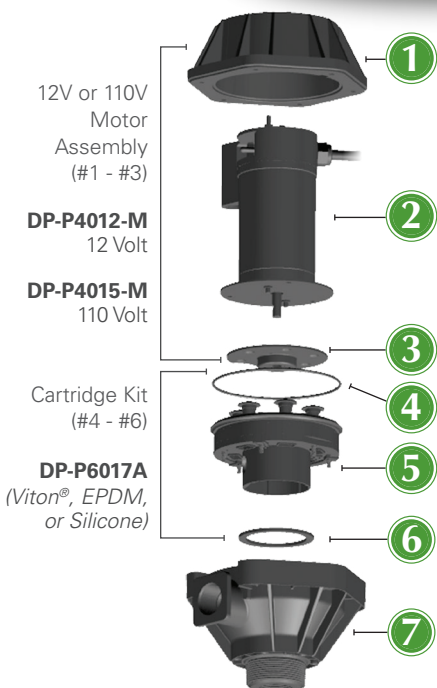

12V or 110V
Motor
Assembly
(#1 - #3)

DP-P4012-M
12 Volt

DP-P4015-M
110 Volt

Cartridge Kit
(#4 - #6)

DP-P6017A
(Viton®, EPDM,
or Silicone)

- 1** Upper Housing
DP-P4002A
- 2** 12V or 110V Motor
- 3** Wobble/Drive Plate **DP-P6013D**
- 4** O-ring
DP-P4004AO (Viton®, EPDM, or Silicone)
- 5** Cartridge
DP-P6017A (Viton®, EPDM, or Silicone)
- 6** Bottom Gasket
DP-P4001AG (Viton®, EPDM, or Silicone)
- 7** Bottom Housing
DP-H4001A (Viton®, EPDM, or Silicone)

- High-Flow with up to 18GPM/68LPM flow rate; a 20% improvement in flow rate over our previous pump
- Newly redesigned, simplified cartridge for easier serviceability
- Self-priming diaphragm pump with internal by-pass
- Motor thermally protected from overheating
- 30-minute duty cycle
- Suction port has 2" Male NPT and 1" Female NPT
- Includes a 2-year Warranty & Maintenance Program

SPECIFICATIONS	
Check Valve	Internal; EPA 165.45 compliant
Vertical Suction Lift	Self-priming to 10ft, 3m
Power Cord	12 Volt: 20ft, 6m; 110 Volt: 6.5ft, 2m
Motor	¼ HP, 186W
Amps	12 Volt: 20; 110 Volt: 3.0
Suction Port	2" Male and 1" Female NPT thread
Discharge Port	1" Female NPT thread
Wetted Materials	Polypropylene; Santoprene; Viton®, EPDM, or Silicone seals; 304 Stainless Steel, PVDF (Kynar®)

ORDERING INFORMATION	
12 VOLT	110 VOLT
DP-6018V-12 Viton®	DP-6018V-110 Viton®
DP-6018E-12 EPDM	DP-6018E-110 EPDM
DP-6018S-12 Silicone	DP-6018S-110 Silicone

Always turn pump off and disconnect system from power when not in use.

DURA-PUMP™ EASY CADDY

Tanks, Totes and Drums sold separately.



SIDE MOUNT
Easy Caddy secured
on side of tote



TOP MOUNT
Easy Caddy secured
on top of tote



GROUND
Easy Caddy used
from the ground



DRUM
Easily converted
to a 30/55-Gallon
Drum

1 SYSTEM USE IT 6 WAYS

- The Easy Caddy can be mounted in six different configurations on a variety of tank/tote and drum types
- Use it mounted on top of a tank or on top of a 30/55-Gallon Drum, on the side of tank, or off the ground depending on user preference
- Conversion kits are available to mount a system on Monsanto or Snyder type tanks
- Includes a 2-year Warranty & Maintenance Program



MONSANTO TANK
Easily converted to a MTS



SNYDER TANK
Easily converted
to a GEM Cap



PUMPING SYSTEM CONTAINS

Pump	High-Flow Dura-Pump™
Suction Hose	1" x 5ft, 1.5m
Discharge Hose	1" x 12ft, 3.6m
Nozzle	Ball valve
Camlock	2"
Meter	Dura-Meter™ (optional)
Other	All hose clamps, barsbs and nipples

ORDERING INFORMATION	
12 VOLT WITH METER	110 VOLT WITH METER
DPEM-6318V-12 Viton®	DPEM-6318V-110 Viton®
DPEM-6318E-12 EPDM	DPEM-6318E-110 EPDM
DPEM-6318S-12 Silicone	DPEM-6318S-110 Silicone
12 VOLT NO METER	110 VOLT NO METER
DPE-6018V-12 Viton®	DPE-6018V-110 Viton®
DPE-6018E-12 EPDM	DPE-6018E-110 EPDM
DPE-6018S-12 Silicone	DPE-6018S-110 Silicone

Always turn pump off and disconnect system from power when not in use.

DURA-PUMP™ EASY CADDY CONVERSION KITS

For Use On **MONSANTO TANK**
MTS Easy Caddy Conversion Kit **DP-AK0008**



1
Begin with the
Dura Easy Caddy



2
Remove Dura-Pump™
from Easy Caddy frame



3
Add MTS Kit
DP-AK0008



Dura MTS Kit
DP-AK0008 installed
on Monsanto tank

For Use On **SNYDER TANK**
GEM Cap Easy Caddy Conversion Kit **DP-AK0009**



1
Begin with the
Dura Easy Caddy



2
Remove Dura-Pump™
from Easy Caddy frame



3
Add GEM Cap Kit
DP-AK0009



Dura GEM Cap Kit
DP-AK0009 installed
on Snyder tank

For Recirculation On **IBC/TOTE**
Recirculation Kit **DP-AK0007**



1
Begin with the
Dura Easy Caddy



2
Add Recirculation Kit
DP-AK0007



3
Dura Recirculation Kit
DP-AK0007 installed
on IBC/TOTE

For Use On **30/55-GALLON DRUM**
1" NPT Telescoping Downtube **DP-T4001**



1
Begin with the
Dura Easy Caddy



2
Remove Dura-Pump™
from Easy Caddy frame



3
Add DP-T4001
1" NPT Telescoping
Downtube



DP-T4001
1" NPT Telescoping
Downtube installed on
30/55-Gallon Drum

DURA-PUMP™ SPECIALTY SYSTEMS

Tanks, Totes and Drums sold separately. Always turn pump off and disconnect from power when not in use.

DURA-PUMP™ QUICK CADDY

- Our premium highly portable system with built-in carry handle and rugged frame
- For use in multiple mounting applications both on top of tote and ground adaptable
- Includes a 2-year Warranty & Maintenance Program



PUMPING SYSTEM CONTAINS	
Pump	High-Flow Dura-Pump™
Suction Hose	1" x 5ft, 1.5m
Discharge Hose	1" x 12ft, 3.6m
Nozzle	Ball valve
Camlock	2"
Meter	Dura-Meter™ (optional)
Other	All hose clamps, bars and nipples

ORDERING INFORMATION

12 VOLT WITH METER	110 VOLT WITH METER	12 VOLT NO METER	110 VOLT NO METER
DPQM-6318V-12 Viton®	DPQM-6318V-110 Viton®	DPQ-6018V-12 Viton®	DPQ-6018V-110 Viton®
DPQM-6318E-12 EPDM	DPQM-6318E-110 EPDM	DPQ-6018E-12 EPDM	DPQ-6018E-110 EPDM

DURA-PUMP™ TOP UNLOAD

- Top mount application with 2" NPT bung, 1" telescoping downtube to accommodate varying tank heights
- Includes a 2-year Warranty & Maintenance Program



PUMPING SYSTEM CONTAINS	
Pump	High-Flow Dura-Pump™
Discharge Hose	1" x 12ft, 3.6m
Downtube	1" Telescoping
Nozzle	Ball valve
Meter	Dura-Meter™ (optional)
Other	All hose clamps, bars and nipples

ORDERING INFORMATION

12 VOLT WITH METER	110 VOLT WITH METER	12 VOLT NO METER	110 VOLT NO METER
DPTM-6318V-12 Viton®	DPTM-6318V-110 Viton®	DPT-6018V-12 Viton®	DPT-6018V-110 Viton®
DPTM-6318E-12 EPDM	DPTM-6318E-110 EPDM	DPT-6018E-12 EPDM	DPT-6018E-110 EPDM

DURA-PUMP™ BOTTOM UNLOAD

- Configured to mount at bottom of tank/tote
- Includes a 2-year Warranty & Maintenance Program



PUMPING SYSTEM CONTAINS	
Pump	High-Flow Dura-Pump™
Discharge Hose	1" x 12ft, 3.6m
Camlock	2"; direct attach to tote
Motor Bracket	Yes, rear
Nozzle	Ball valve
Meter	Dura-Meter™ (optional)
Other	All hose clamps, bars and nipples

ORDERING INFORMATION

12 VOLT WITH METER	110 VOLT WITH METER	12 VOLT NO METER	110 VOLT NO METER
DPBM-6318V-12 Viton®	DPBM-6318V-110 Viton®	DPB-6018V-12 Viton®	DPB-6018V-110 Viton®
DPBM-6318E-12 EPDM	DPBM-6318E-110 EPDM	DPB-6018E-12 EPDM	DPB-6018E-110 EPDM

DURA-PUMP™ SPECIALTY SYSTEMS

Tanks, Totes and Drums sold separately. Always turn pump off and disconnect from power when not in use.

MONSANTO TANK

- Includes a 2-year Warranty & Maintenance Program



For use with Monsanto tanks



PUMPING SYSTEM CONTAINS	
Pump	High-Flow Dura-Pump™
Discharge Hose	1" x 12ft, 3.6m
Camlock	MTS; direct attach to tote
Motor Bracket	Yes, rear
Nozzle	Ball valve
Meter	Dura-Meter™ (optional)
Other	All hose clamps, bars and nipples

ORDERING INFORMATION

12 VOLT WITH METER	110 VOLT WITH METER	12 VOLT NO METER	110 VOLT NO METER
DPMTSM-6318V-12 Viton®	DPMTSM-6318V-110 Viton®	DPMTS-6018V-12 Viton®	DPMTS-6018V-110 Viton®
DPMTSM-6318E-12 EPDM	DPMTSM-6318E-110 EPDM	DPMTS-6018E-12 EPDM	DPMTS-6018E-110 EPDM

SNYDER / GEM CAP TANK

- Includes a 2-year Warranty & Maintenance Program



For use with Snyder tanks with large 8" lid



PUMPING SYSTEM CONTAINS	
Pump	High-Flow Dura-Pump™
Discharge Hose	1" x 12ft, 3.6m
GEM Cap Lid	Spin collar; all plumbing assembled on pump
Motor Bracket	Yes; rear
Downtube	1" Telescoping
Nozzle	Ball valve
Meter	Dura-Meter™ (optional)
Other	All hose clamps, bars and nipples

ORDERING INFORMATION

12 VOLT WITH METER	110 VOLT WITH METER	12 VOLT NO METER	110 VOLT NO METER
DPGEMM-6318V-12 Viton®	DPGEMM-6318V-110 Viton®	DPGEM-6018V-12 Viton®	DPGEM-6018V-110 Viton®
DPGEMM-6318E-12 EPDM	DPGEMM-6318E-110 EPDM	DPGEM-6018E-12 EPDM	DPGEM-6018E-110 EPDM



N-SERVE EASY CADDY

- Includes a 2-year Warranty & Maintenance Program



Female Coupling
Dry Poppet
DP-TMQD100F
sold separately

PUMPING SYSTEM CONTAINS	
Pump	High-Flow Dura-Pump™
Discharge Hose	1" x 12ft, 3.6m; Premium XLPE
Suction Hose	1" x 5ft, 1.5m; Premium XLPE
Dry-Poppet Coupler	Available; sold separately (see right)
Nozzle	Ball valve
Meter	Dura-Meter™ (optional)
Other	All hose clamps, bars & nipples

ORDERING INFORMATION	
WITH METER	WITHOUT METER
DPEM-6618NV-12 12 Volt	DPE-6618NV-12 12 Volt
DPEM-6618NV-110 110 Volt	DPE-6618NV-110 110 Volt

Easy Caddy pumping system in Viton®

N-SERVE BOTTOM UNLOAD

- Includes a 2-year Warranty & Maintenance Program



Female Coupling
Dry Poppet
DP-TMQD100F
sold separately

PUMPING SYSTEM CONTAINS	
Pump	High-Flow Dura-Pump™
Discharge Hose	1" x 12ft, 3.6m; Premium XLPE
Motor Bracket	Yes; rear
Dry-Poppet Coupler	Available; sold separately (see right)
Nozzle	Ball valve
Meter	Dura-Meter™ (optional)
Other	All hose clamps, bars & nipples

ORDERING INFORMATION	
WITH METER	WITHOUT METER
DPBM-6318NV-12 12 Volt	DPB-6018NV-12 12 Volt
DPBM-6318NV-110 110 Volt	DPB-6018NV-110 110 Volt

Bottom Unload pumping system in Viton®



DEF DURA-METER™

- Made of impact resistant Lexan™ faceplate
- 100% moisture-sealed circuitry
- Same great menu driven backlit display
- Plumbed for both in-line and 90 degree applications
- Includes a 2-year Warranty & Maintenance Program



ORDERING INFORMATION
DP-3000D

SPECIFICATIONS

Operating Temp	-10°F to 130°F, -23°C to 54°C
Flow Rate	2 to 20GPM, 7.5 to 75.7LPM
ISO22241-3 Compliant	Yes
Meter Accuracy	+ / - .5%
Maximum Pressure	40 PSI
Wetted Materials	Polypropylene; 304 Stainless Steel; Ryton; EPDM seals



DEF DURA-PUMP™

- High-Flow pump with up to 18GPM/68LPM free flow rate and 15+GPM/56+LPM with ¾" discharge hose and nozzle
- Self-priming diaphragm pump with internal bypass
- Motor thermally protected from overheating
- 30-minute duty cycle
- Suction port has 2" Male NPT and 1" Female NPT
- Pump is easily field serviceable
- 10-minute auto-shut off motor (available in 110V only)
- Includes a 2-year Warranty & Maintenance Program

ORDERING INFORMATION

DEF-6018E-12 12 Volt **DEF-6018E-110** 110 Volt

SPECIFICATIONS

Check Valve	Internal; EPA 165.45 compliant
Vertical Suction Lift	Self-priming to 10ft, 3m
Power Cord	12 Volt: 20ft, 6m; 110 Volt: 6.5ft, 2m
Motor	¼ HP, 186W
Amps	12 Volt: 20; 110 Volt: 3.0
Suction Port	2" Male and 1" Female NPT thread
Discharge Port	1" Female NPT thread
ISO22241-3 Compliant	Yes
Wetted Materials	Polypropylene; Santoprene; PVDF (Kynar®); 304 Stainless Steel; EPDM seals

DEF DURA-PUMP™ EASY CADDY TOP SUCTION

For totes with RPV type valve

PUMPING SYSTEM CONTAINS	
15+GPM Pump	High-Flow Dura-Pump™
Coupler	RPV; MicroMatic
Discharge Hose	¾" x 18ft, 5.5m
Suction Hose	¾" x 1.5ft, 0.5m
Nozzle	Manual or Automatic
Meter	DEF Dura-Meter™ (optional)
Other	All hose clamps & fittings

· Includes a 2-year Warranty & Maintenance Program

DEF DURA-PUMP™ TOP UNLOAD

PUMPING SYSTEM CONTAINS	
15+GPM Pump	High-Flow Dura-Pump™
Downtube	1" Telescoping
Nozzle	Manual or Automatic
Discharge Hose	¾" x 18ft, 5.5m
Meter	DEF Dura-Meter™ (optional)
Other	All hose clamps & fittings

· Includes a 2-year Warranty & Maintenance Program

DEF DURA-PUMP™ 135 PORTABLE TOTE COMPLETE SYSTEM to TRANSPORT, DISPENSE & STORE DIESEL EXHAUST FLUID

PUMPING SYSTEM CONTAINS	
135-Gallon Tote	Specially designed to maintain the strictest purity of DEF
Pump System	ISO/EPA compliant DEF Easy Caddy pumping system
Coupler	RPV; MicroMatic
Discharge Hose	¾" x 18ft, 5.5m
Suction Hose	¾" x 1.5ft, 0.5m
Lid	6"; Vented
Nozzle	Manual or Automatic
Meter	DEF Dura-Meter™ (optional)
Other	All hose clamps & fittings

· Includes a 2-year Warranty & Maintenance Program



ORDERING INFORMATION

MANUAL NOZZLE

DEFE-6518ME-12 12 Volt

DEFE-6518ME-110 110 Volt

AUTOMATIC NOZZLE

DEFE-6518AE-12 12 Volt

DEFE-6518AE-110 110 Volt

DEF Dura-Meter™
DP-3000D (sold separately)

TOP MOUNT

Easy Caddy secured on top of a 330 tote



Meter, Totes, Drums, Lid and Container Valves sold separately.

ORDERING INFORMATION

MANUAL NOZZLE

DEFT-6018ME-12 12 Volt

DEFT-6018ME-110 110 Volt

AUTOMATIC NOZZLE

DEFT-6018AE-12 12 Volt

DEFT-6018AE-110 110 Volt

DEF Dura-Meter™
DP-3000D (sold separately)



Meter, Totes, Drums and Lid sold separately.



ORDERING INFORMATION

MANUAL NOZZLE

DEFE-6518ME-12-135 12 Volt

DEFE-6518ME-110-135 110 Volt

AUTOMATIC NOZZLE

DEFE-6518AE-12-135 12 Volt

DEFE-6518AE-110-135 110 Volt

DEF Dura-Meter™
DP-3000D (sold separately)

ALL- IN-1



Tote, Lid and Container Valve INCLUDED.

DURA AUTO-BATCH™ METER

Upgrade your DURA-PUMP™
to an AUTO-BATCH SYSTEM



ORDERING INFORMATION

PRODUCT

DPAB-12V Viton® 12 Volt

DPAB-12E EPDM 12 Volt

DPAB-15V Viton® 110 Volt

DPAB-15V EPDM 110 Volt

*Always turn pump off and disconnect
system from power when not in use.*

Never leave unattended while in use.



Video available at
DuraProducts.com/videos

AG ACCESSORIES, PARTS, REPAIR KITS & TANKS



AG Dura-Pump™
Gasket Kit
DP-G4001A-V Viton®
DP-G4001A-E EPDM
DP-G4001A-S Silicone



AG Dura-Pump™ Bottom Housing Kit
with Bottom Gasket and Screws
DP-H4001A-V Viton®
DP-H4001A-E EPDM
DP-H4001A-S Silicone



AG Dura-Pump™ Cartridge Kit
with O-Ring and Bottom Gasket
DP-P6017A-V Viton®
DP-P6017A-E EPDM
DP-P6017A-S Silicone



AG Dura-Meter™
Chemical Face Plate
DP-MFP01
DP-MFP01-ABS Auto-Batch™



AG Dura-Meter™ Body
DP-PMB3000V Viton®
DP-PMB3000E EPDM
DP-PMB3000S Silicone



RSV / 3 Key
Dispense Coupler,
Viton Seals
DP-R4003



5-Gallon Calibration Jug
DP-CALJUG



2" Camlock
DP-TM20CL



MTS Camlock
DP-M4001



135-Gallon Tank
DP-AG135

DURA PRODUCTS AG CHEMICAL CHART

COMPOUND	EPDM	Viton®	Silicone
2,4-D Ester		●	
Accord® / Accord® XRT II	●	●	●
Acuron®	●		
Ammonium Sulfate	●	●	●
Atrazine	●	●	
Balance® Flexx	●	●	
Boundary®		●	
Callisto® 480SC	●		
Capreno®	●	●	
Corvus®	●	●	
Degree Xtra®	●	●	
Dicamba / Xtendimax®	●		
DiFlexx® Duo	●	●	
Duramax® / Durango®	●	●	●
Engenia®	●		
Enlist Duo®	●	●	●
EverGol®	●	●	
Foliars		●	
ForeFront®	●		
FulTime® NXT		●	
Fungicides		●	
Garlon® 3A	●		●
Gaicho® 600	●	●	
Gramoxone® / Paraquat		●	
Grazon® P+D / GrazonNext	●		
Halex® GT	●		
Huskie®		●	
Instinct®			●

COMPOUND	EPDM	Viton®	Silicone
Intimidator®	●		●
Keystone® / Keystone® LA			●
Laudis®	●	●	
Lexar® EZ / Lumax® EZ	●		
Liberty®	●		
Lorsban® 4E / Lorsban® Advanced		●	
Matador®	●		●
Max-In® Ultra ZMB	●	●	
MSO / Crop Oil / Oil Based		●	
Nitrogen Based		●	
N-Serve® 24		●	
Parity™		●	
Prosaro®	●	●	
Prowl® / Pendimethalin		●	
Raxil® PRO	●	●	
Rely® 280	●	●	
Resicore®			●
Roundup®	●	●	
Shredder™ E-99		●	
Stratego® / Stratego® YLD	●		
Stylet-Oil		●	
SureStart® / SureStart® II			●
Surpass® EC	●		●
Tacoma®		●	
TopNotch®	●		
Tordon® 22k	●		
Warrant®		●	
Wolverine® Advanced		●	

The Dura Products Chemical Compatibility Chart **should be considered as a guide only** due to the many variables which may affect the compatibility of materials. This guide is based on the most recent information obtained from a variety of suppliers and chemical producers and is believed to be accurate. Actual decisions on materials used need to be tested and evaluated by the customer for each specific application. The responsibility of proper chemical compatibility of equipment and material used is the full responsibility of the customer. Dura Products does not warrant product damaged by non compatibility.

For help with the proper selection of a pump for your application needs, please call **(317) 984-4003**.



DURA PRODUCTS
Technology with Lasting Value

PO Box 380
504 Demoss Ave
Arcadia, IN 46030
(317) 984-4003

www.DuraProducts.com



DP_AG_MINI_0324